

Technical Data Sheet

Shopster Basic trolley # 3 (flat pack)

International Article Number

178372

Product classification

Trolley Equipment (Shopster)

Composition

Metal parts: Stainless steel, aluminium

Plastic parts: Polypropylene

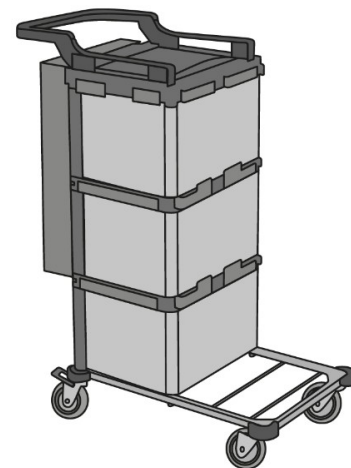

Technical data

	Typical value	Unit
Weight	9180	g
Width	64	cm
Length	44.5	cm
Height	90	cm

Product properties and product usage

- Basement in stainless steel and 2 aluminum U-bars
- Equipped with 100mm castors, including two with brakes.
- Features a separated, lockable compartment for boxes, trays or waste (2x35L, 1x70L).
- Includes a lockable top lid.
- Includes a lockable cupboard cabinet
- Comes with a height-adjustable push bar.
- High durability and stability.

Storage, transportation and disposal

Keep palletized products in a cold and dry place. Avoid exposure to direct sunlight. Product is not subject to transportation regulations for hazardous substances or chemicals. Disposal via landfill or incineration possible. Please respect local regulations.

Quality approvals / compliance with international standards

This product is compliant to our internal quality standards and external regulations

Date: 2024/11/30

ALL INFORMATION CONTAINED HEREIN IS GIVEN ON AN "AS IS" BASIS AND BASED ON OUR CURRENT KNOWLEDGE. NO WARRANTY, WRITTEN OR ORAL, EXPRESSED OR IMPLIED IS GIVEN BY US OR MAY BE INFERRED FROM A COURSE OF DEALING OR USAGE OF TRADE NEITHER BASED ON ADVERTISEMENTS, CONCLUDING ACTION NOR COMMERCIAL USE. TO THE EXTENT ALLOWED BY LOCAL LAW WE DISCLAIM ALL IMPLIED WARRANTIES OR CONDITIONS INCLUDING ANY IMPLIED WARRANTIES OF MERCHANTABILITY AND FITNESS FOR A PARTICULAR PURPOSE, AND WARRANTIES OF NON-INFRINGEMENT. TECHNICAL DATA ARE TYPICAL VALUES AND SUBJECT TO A CERTAIN TOLERANCE AND VARIATIONS AND CAN BE CHANGED WITHOUT FURTHER PRIOR NOTICE. SOLELY THE CUSTOMER SHALL BE RESPONSIBLE TO ASSESS THE SUITABILITY OF OUR PRODUCTS FOR ANY INTENDED USES AS WELL AS ALL RELEVANT HEALTH, SAFETY AND ENVIRONMENT PROPERTIES AND RISKS.